

# Guide to Assembly & Usage

## Boltless 300kg Workbench

**Information**  
If in doubt, contact the supplier

Read this Guide thoroughly before commencing assembly & retain for future reference

Before commencing assembly, unpack carefully & check that all components ordered are included

Assembly should be undertaken by two competent people

Tools – Rubber faced mallet, screwdriver, or other flat bladed tool

**Caution**  
During assembly, ensure to:

Take care during assembly & in use, particularly when lifting or stretching & when using tools

Wear suitable protective clothing - protective gloves and footwear are recommended

Assemble & locate for use on a suitable level floor surface. Allow adequate working space

Dispose of packaging materials responsibly

**Warning**  
Rules for the safe use of workbenches:

Ensure these instructions are retained for reference & that users are aware of the rules for safe use

NEVER CLIMB ON THE STRUCTURE OR STAND ON THE SHELVES

DO NOT LEAN OR SUPPORT LADDERS, STEPS, OR OTHER OBJECTS AGAINST WORKBENCH

DO NOT USE IN DAMP OR WET CONDITIONS





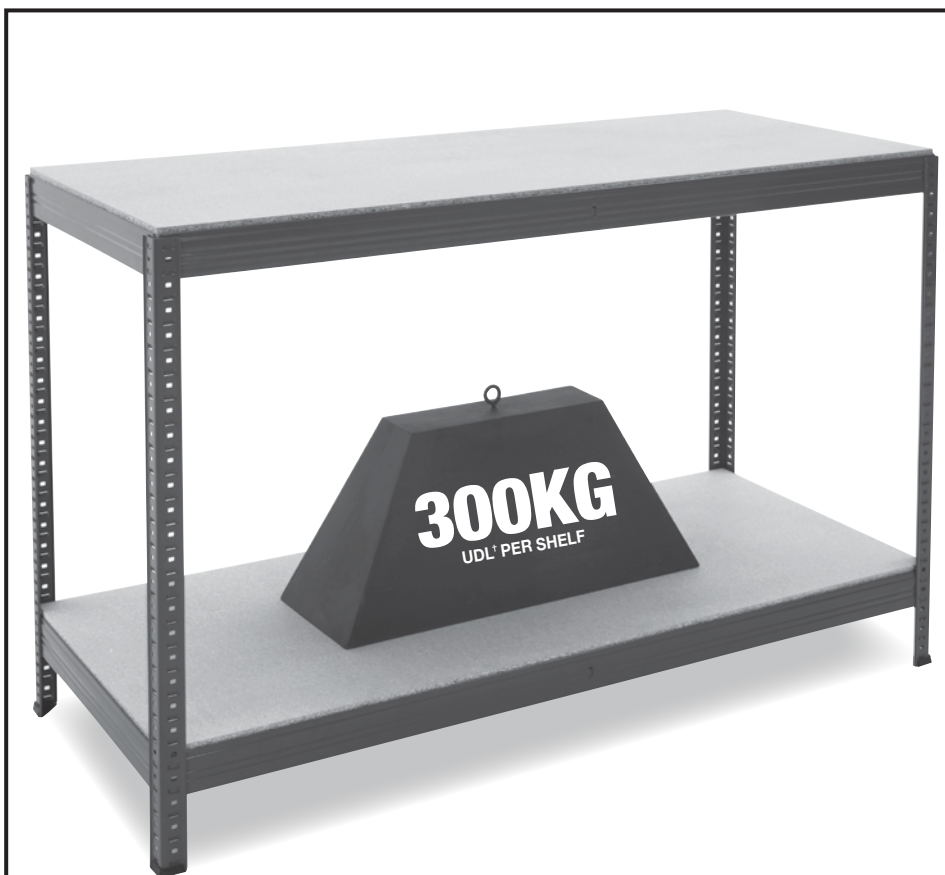

LOAD HEAVY ITEMS ON THE LOWER SHELVES & LIGHTER ITEMS ON THE HIGHER SHELVES

ENSURE THAT THE MAXIMUM LOAD CARRYING CAPACITIES ARE NOT EXCEEDED

PLEASE REFER TO THE LOADING CHART SUPPLIED FOR DETAILS



### COMPONENT CHECK LIST

Component	Quantity
Upright 	4
Front & Back Beam 	4
Side Beam 	4
Centre Support 	1000mm/ 1200mm/ 1400mm = 2 1800mm = 4
Chipboard 	2
Feet 	4

If you have any missing components please take note of the part name, and contact your supplier

# Boltless 300kg Workbench Assembly

**1.** Slot first short beam into post. Tap into place with rubber mallet

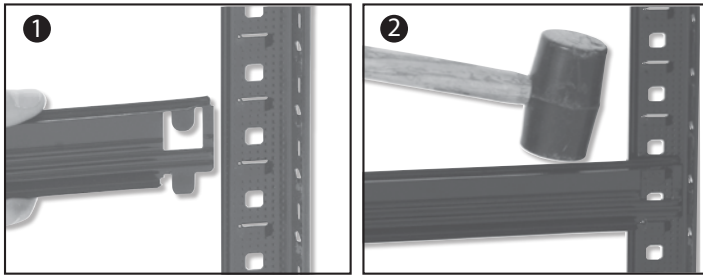

**2.** Assemble end frames with short beams & join with long front & back beams

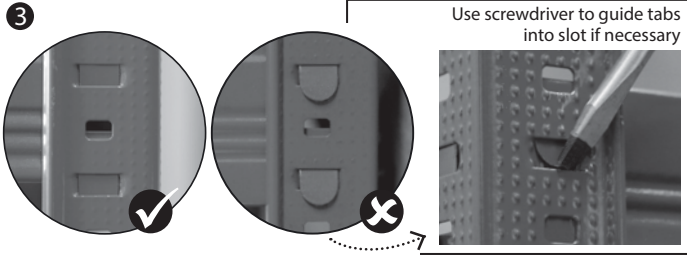
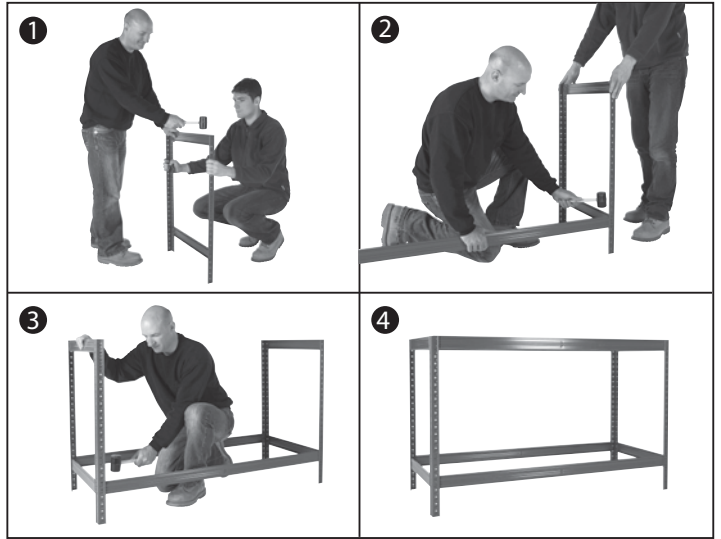

**3.** Bend centre support ends at right angles. Slot into long beams.

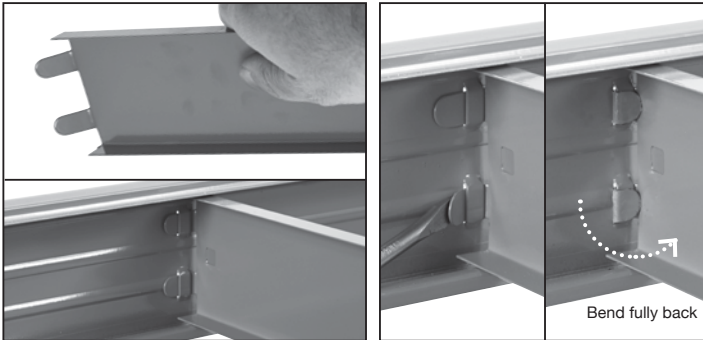

**4.** Insert particleboard decks onto steel frame

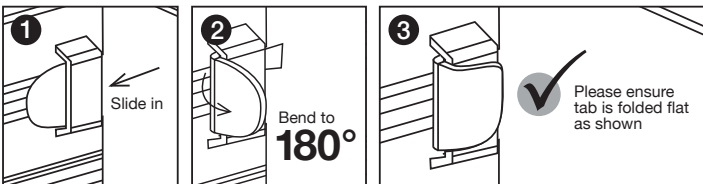

**5.** Push plastic protective feet onto each post

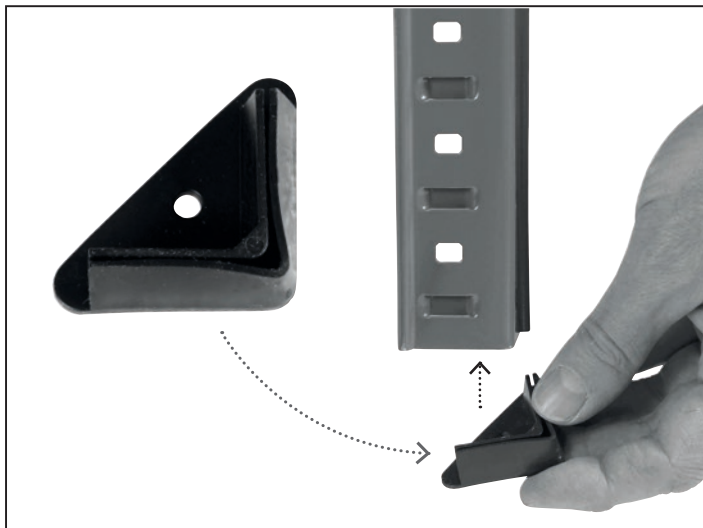

## LOADING CHART

