

# Guide to Assembly & Usage

## BiG400 T Bar Workstation



### Information

If in doubt, contact the supplier



Read this Guide thoroughly before commencing assembly & retain for future reference



Before commencing assembly, unpack carefully & check that all components ordered are included



Assembly should be undertaken by two competent people



Tools – Rubber faced mallet



Assess for floor fixing. Tall narrow bays may require this to ensure stability



### Caution

During assembly, ensure to:



Take care during assembly & in use, particularly when lifting or stretching & when using tools



Assemble & locate for use on a suitable level floor surface. Allow adequate working space



Dispose of packaging materials responsibly



### Warning

Rules for the safe use of workstations:



Ensure these instructions are retained for reference & that users are aware of the rules for safe use



NEVER CLIMB ON THE STRUCTURE OR STAND ON THE SHELVES



DO NOT LEAN OR SUPPORT LADDERS, STEPS, OR OTHER OBJECTS AGAINST WORKSTATION



ALWAYS USE SAFETY STEPS TO REACH HIGH SHELVES



Do not use in damp or wet conditions



Load heavy items on the lower shelves & lighter items on the higher shelves



This product is designed for hand loading only



ENSURE THAT THE MAXIMUM LOAD CARRYING CAPACITIES ARE NOT EXCEEDED



PLEASE REFER TO THE LOADING CHART SUPPLIED FOR DETAILS

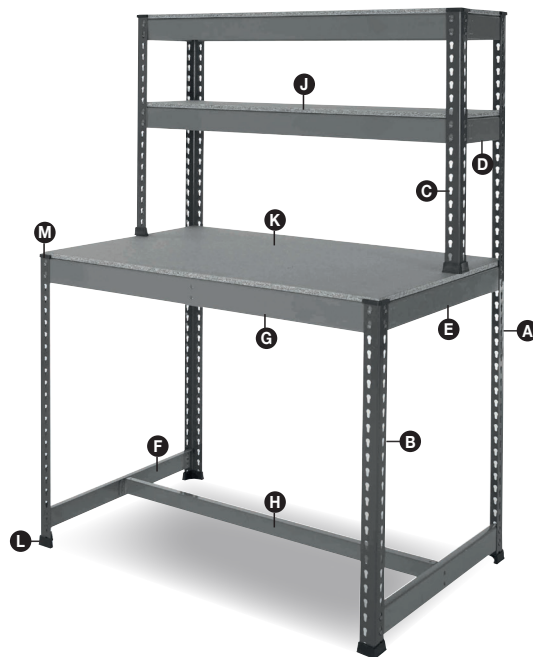

### COMPONENT CHECK LIST

| Component  | Quantity |
|--|----------|
| <b>A</b> Upright 1677mm High                                     | 2        |
| <b>B</b> Upright 915mm high                                      | 2        |
| <b>C</b> Upright 746mm high                                      | 2        |
| <b>D</b> Side Beam 305mm long                                    | 4        |
| <b>E</b> Side Beam (Varies according to depth)                   | 2        |
| <b>F</b> Side Beam with centre clips (Varies according to depth) | 2        |
| <b>G</b> Front & Back Beam (Varies according to width)           | 6        |
| <b>H</b> Foot rest (Varies according to depth)                   | 1        |
| <b>I</b> Centre Support (Varies according to depth)              | 1        |
| <b>J</b> Chipboard Top Shelf                                     | 2        |
| <b>K</b> Chipboard Worktop                                       | 1        |
| <b>L</b> Plastic Protective Foot                                 | 6        |
| <b>M</b> Plastic Top Cap   | 6        |

If you have any missing components please take note of the part name and contact your supplier

# Assembly - BiG400 T Bar Workstation

**1** Push a plastic foot **L** onto the base of all 6 uprights **A+B+C**

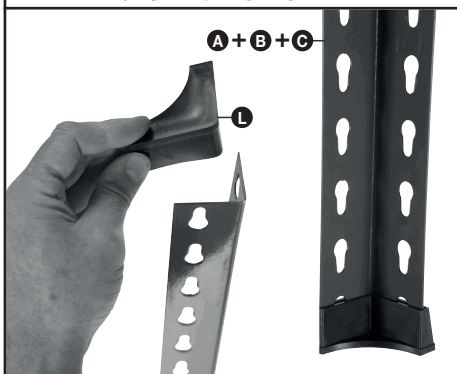

**2** Create one end frame by joining a 1677mm long **A** and 915mm long upright **B** with 2 side beams **E+F** as shown. Ensure the bottom beam **F** has the centre clips for the foot rest. Tap into place with a rubber mallet to ensure the end studs are fully located in the bottom of the keyholes

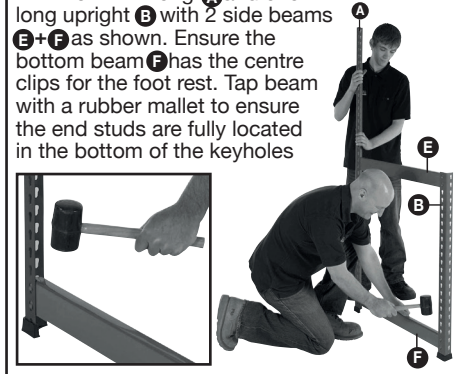

**3** Take the centre foot rest **H** and locate onto the centre studs on the lower beam **F**. Tap into place with a rubber mallet



**4** Build a second end frame as in Step 2, but handed the opposite way. Join this to the centre foot rest as in step 3



**5** Add 2 more front & back beams **G** at worktop height and tap into place



**6** Locate the centre support **I** onto the studs in the long top beams **C** and tap into place

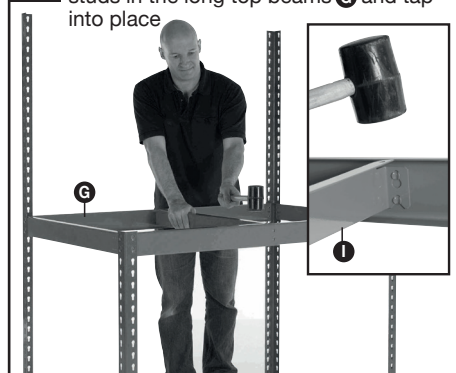

**7** Place the large chipboard deck **K** onto the top beams to create the worktop



**8** Stand one of the 746mm uprights **C** onto the bench top and join to the rear upright **A** with a 305mm side beam **D**. Repeat with a second side beam for the top shelf

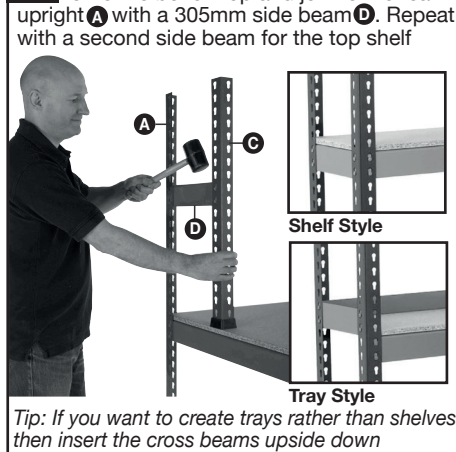

*Tip: If you want to create trays rather than shelves then insert the cross beams upside down*

**9** Repeat step 8 on the opposite side and join together with 4 front & back beams **G**



**10** Insert chipboard decks **J** into place on both top levels

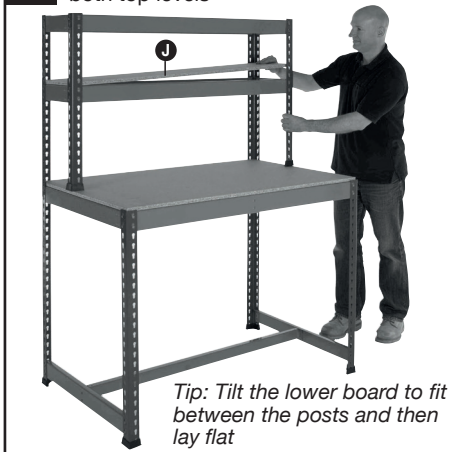

*Tip: Tilt the lower board to fit between the posts and then lay flat*

**11** Push protective plastic caps **L** onto the top of each upright to complete the workstation



**12** Optional steel feet are also available with levelling Shims. Simply bolt each foot to the bottom hole in the upright using nuts, washers and bolts provided. Position the bench and add shims under feet to level if needed. Feet can also be bolted to the floor using 70mm sleeve anchors

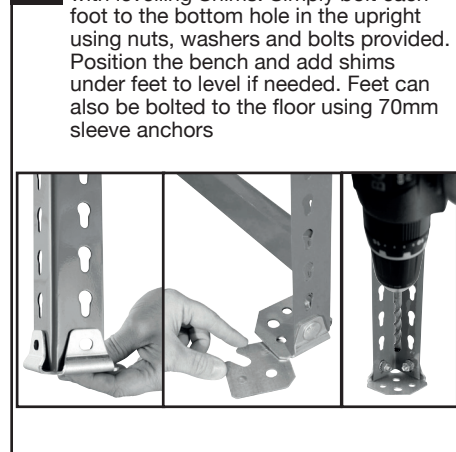

# Assembly - BiG400 T Bar Workstation

## Loading information

### BiG400 T Bar Workstation

These load charts relate to workstations with the following specifications:

- Maximum post height = 1677 mm
- Single benches and multiple linked benches with a minimum of 2 levels per bay
- Similar distances (height) between levels
- Benches are positioned on a level floor

For any other layouts, please refer to your supplier for detailed loading capacities

#### Bench Load Capacities

The maximum load permitted is 400kgs total for workstations.

#### Shelf load capacities

Maximum permitted shelf capacities are based on uniformly distributed loads (UDL). Please note that the above bench capacity may limit the maximum load per shelf:

| Shelf width mm | Capacity with 15mm Chipboard decks |
|----------------|------------------------------------|
| Top Shelves    | 100kg                              |
| Worktop        | 400kg                              |

Capacities are common for all standard shelf depths

**IF YOU ARE IN ANY DOUBT REGARDING LOAD CAPACITIES, PLEASE CONTACT YOUR SUPPLIER**